



Visualisation; Diagnostics

Easy to Configure

Programming IEC 61131-3

Rapid Installation

PSS u2 ES 4DO R 8A

PILZ

THE SPIRIT OF SAFETY

- ▶ Control system PSS u2
- ▶ Remote I/O system PSS u2

This document is the original document.

All rights to this documentation are reserved by Pilz GmbH & Co. KG. Copies may be made for the user's internal purposes. Suggestions and comments for improving this documentation will be gratefully received.

Source code from third-party manufacturers or open source software has been used for some components. The relevant licence information is available on the Internet on the Pilz homepage.

Pilz®, PIT®, PMI®, PNOZ®, Primo®, PSEN®, PSS®, PVIS®, SafetyBUS p®, SafetyEYE®, SafetyNET p®, the spirit of safety® are registered and protected trademarks of Pilz GmbH & Co. KG in some countries.



SD means Secure Digital

Section 1	Introduction	5	
	1.1	Validity of documentation	5
	1.1.1	Retaining the documentation	5
	1.2	Using the documentation	5
	1.3	Definition of symbols	5
Section 2	Overview	7	
	2.1	Module features	7
Section 3	Safety	8	
	3.1	Intended use	8
	3.2	System requirements	8
	3.3	Safety regulations	8
	3.3.1	Use of qualified personnel	8
	3.3.2	Warranty and liability	9
	3.3.3	Disposal	9
Section 4	Function description	10	
	4.1	Block diagram	10
	4.2	Supply	10
	4.3	Integrated protection mechanisms	10
	4.4	Outputs	11
	4.5	Reaction times	11
	4.6	Energy-saving functions	11
Section 5	Address assignment	12	
Section 6	Installation	13	
	6.1	General installation guidelines	13
	6.1.1	Dimensions	13
	6.2	Protective coding on terminal block	13
	6.3	Inserting and removing an electronic module	15
	6.3.1	Inserting an electronic module	15
	6.3.2	Removing an electronic module	17
	6.3.3	Changing an electronic module during operation	17
Section 7	Wiring	19	
	7.1	General wiring guidelines	19
	7.1.1	Connection mechanism for terminal blocks	19
	7.2	Terminal configuration	20
Section 8	Operation	21	
	8.1	Display elements and messages	21
Section 9	Technical Details	23	
	9.1	Service life graphs	25

Section 10	Order reference	26
	10.1 Product	26
	10.2 Accessories	26

1 Introduction

1.1 Validity of documentation

This operating manual explains the function and operation, describes the installation and provides guidelines on how to connect the product.

This documentation is valid for the product PSS u2 ES 4DO R 8A. It is valid until new documentation is published.

1.1.1 Retaining the documentation

This documentation is intended for instruction and should be retained for future reference.

1.2 Using the documentation

This document is intended for instruction. Only install and commission the product if you have read and understood this document. The document should be retained for future reference.

Please refer to the PSS u2 Installation Manual.

1.3 Definition of symbols

Information that is particularly important is identified as follows:



DANGER!

This warning must be heeded! It warns of a hazardous situation that poses an immediate threat of serious injury and death and indicates preventive measures that can be taken.



WARNING!

This warning must be heeded! It warns of a hazardous situation that could lead to serious injury and death and indicates preventive measures that can be taken.



CAUTION!

This refers to a hazard that can lead to a less serious or minor injury plus material damage, and also provides information on preventive measures that can be taken.

**NOTICE**

This describes a situation in which the product or devices could be damaged and also provides information on preventive measures that can be taken. It also highlights areas within the text that are of particular importance.

**INFORMATION**

This gives advice on applications and provides information on special features.

2 Overview

Module structure:

A module consists of

- ▶ An electronic module
- ▶ A terminal block with cage clamp terminals and
- ▶ A backplane

The electronic modules are plugged into the backplane and determine the function. The backplane is used for communication between the head module and the electronic modules and forms the carrier unit for the electronic modules. The terminal block is plugged into the electronic modules and is used to connect the field wiring.

Details of the terminal blocks that can be used are available under "Intended Use".

2.1 Module features

Application of the product PSS u2 ES 4DO R 8A:

Electronic module with relay outputs for standard applications

The product has the following features:

- ▶ 4 relay contacts
 - N/O contact
 - Volt-free
 - Current load capacity per output: See chapter [Service life graphs](#) [ 25]
- ▶ Energy-saving functions
- ▶ LEDs for:
 - Switch status of each output
 - Module error

3 Safety

3.1 Intended use

The module provides relay outputs. It may be used to switch:

- ▶ Resistive loads
- ▶ Inductive loads

The module PSS u2 ES 4DO R 8A may be used in conjunction with the following terminal block:

- ▶ 8-pin terminal block

Intended use includes making the electrical installation EMC-compliant. The module is designed for use in an industrial environment. Interference may occur if used in other areas.

The following is deemed improper use in particular

- ▶ Any component, technical or electrical modification to the module,
- ▶ Use of the module outside the areas described in this manual,
- ▶ Any use of the module that is not in accordance with the technical details.

3.2 System requirements



INFORMATION

The module is supported by

- ▶ PASconfig from version 2.0.0
 - We recommend that you always use the latest version (download from www.pilz.com).

3.3 Safety regulations

3.3.1 Use of qualified personnel

The products may only be assembled, installed, programmed, commissioned, operated, maintained and decommissioned by competent persons.

A competent person is someone who, because of their training, experience and current professional activity, has the specialist knowledge required to test, assess and operate the work equipment, devices, systems, plant and machinery in accordance with the general standards and guidelines for safety technology.

It is the company's responsibility only to employ personnel who

- ▶ Are familiar with the basic regulations concerning health and safety / accident prevention,
- ▶ Have read and understood the information provided in this description under "Safety",
- ▶ And have a good knowledge of the generic and specialist standards applicable to the specific application.

3.3.2 Warranty and liability

All claims to warranty and liability will be rendered invalid if

- ▶ The product was used contrary to the purpose for which it is intended,
- ▶ Damage can be attributed to not having followed the guidelines in the manual,
- ▶ Operating personnel are not suitably qualified,
- ▶ Any type of modification has been made (e.g. exchanging components on the PCB boards, soldering work etc.).

3.3.3 Disposal

- ▶ When decommissioning, please comply with local regulations regarding the disposal of electronic devices (e.g. Electrical and Electronic Equipment Act).

4 Function description

4.1 Block diagram

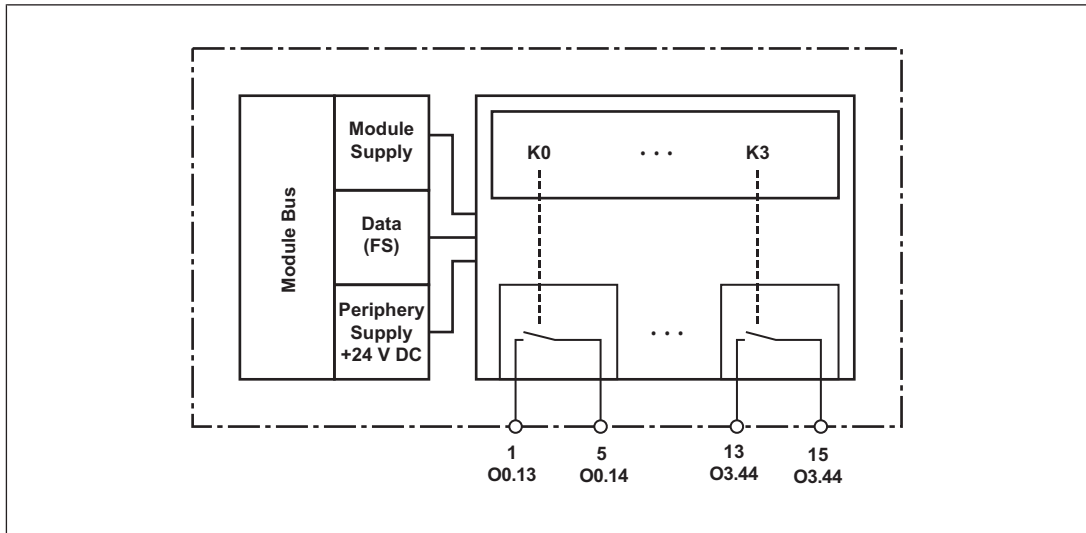

Fig.: Block diagram PSS u2 ES 4DO R 8A

4.2 Supply

- ▶ The module supply provides the module with voltage.

4.3 Integrated protection mechanisms

The module has the following protection mechanisms:

- ▶ Protective separation between both relay contacts (see [Technical details \[📖 23\]](#))
- ▶ Protective separation between both relay contacts and the periphery supply as well as the module supply, in accordance with DIN VDE 0110 overvoltage category 2 in a protected industrial network
- ▶ Temperature monitoring

The module provides the following diagnostic data:

- ▶ Start-up error
- ▶ Configuration error
- ▶ ST communication error
- ▶ Temperature warning: too warm
- ▶ Temperature error: too hot

4.4 Outputs

Outputs

- ▶ The head module sets the output status via the module bus.

If the module does not receive a process image of outputs from the head module, then substitute values are used for the process data. The value that is to be used as the substitute value can be configured.

Substitute values may be:

- ▶ Output switched off (default value)
- ▶ Output switched on
- ▶ Last valid value

4.5 Reaction times

You can find information about the reaction times in the operating manual for the head module PSS u2 P0 F/S PN.

4.6 Energy-saving functions

The energy-saving levels are controlled by the head module and are not configurable. The module supports the following energy-saving levels:

- ▶ Switching off the LEDs
 - The LEDs have two energy-saving levels:
 - Switching off the LEDs that display the terminal status
 - Switching off the LEDs that display the module and terminal status
- ▶ Switching off the relay coils
- ▶ Standby mode
 - All module functions are inactive.
 - The LEDs for displaying the module and terminal status are switched off.

5 Address assignment

The module occupies 1 Byte in the process image of outputs.

PIO	Meaning	State
Bit 0	Output data O0 N/O contact O0.13/O0.14	0: N/O contact is open 1: N/O contact closed
Bit 1	Output data O1 N/O contact O1.23/O1.24	
Bit 2	Output data O2 N/O contact O2.33/O2.34	
Bit 3	Output data O3 N/O contact O3.43/O3.44	
Bit 4-7	None	Permanently "0"

6 Installation

6.1 General installation guidelines



NOTICE

Damage due to electrostatic discharge!

Electrostatic discharge can damage components. Ensure against discharge before touching the product, e.g. by touching an earthed, conductive surface or by wearing an earthed armband.

6.1.1 Dimensions

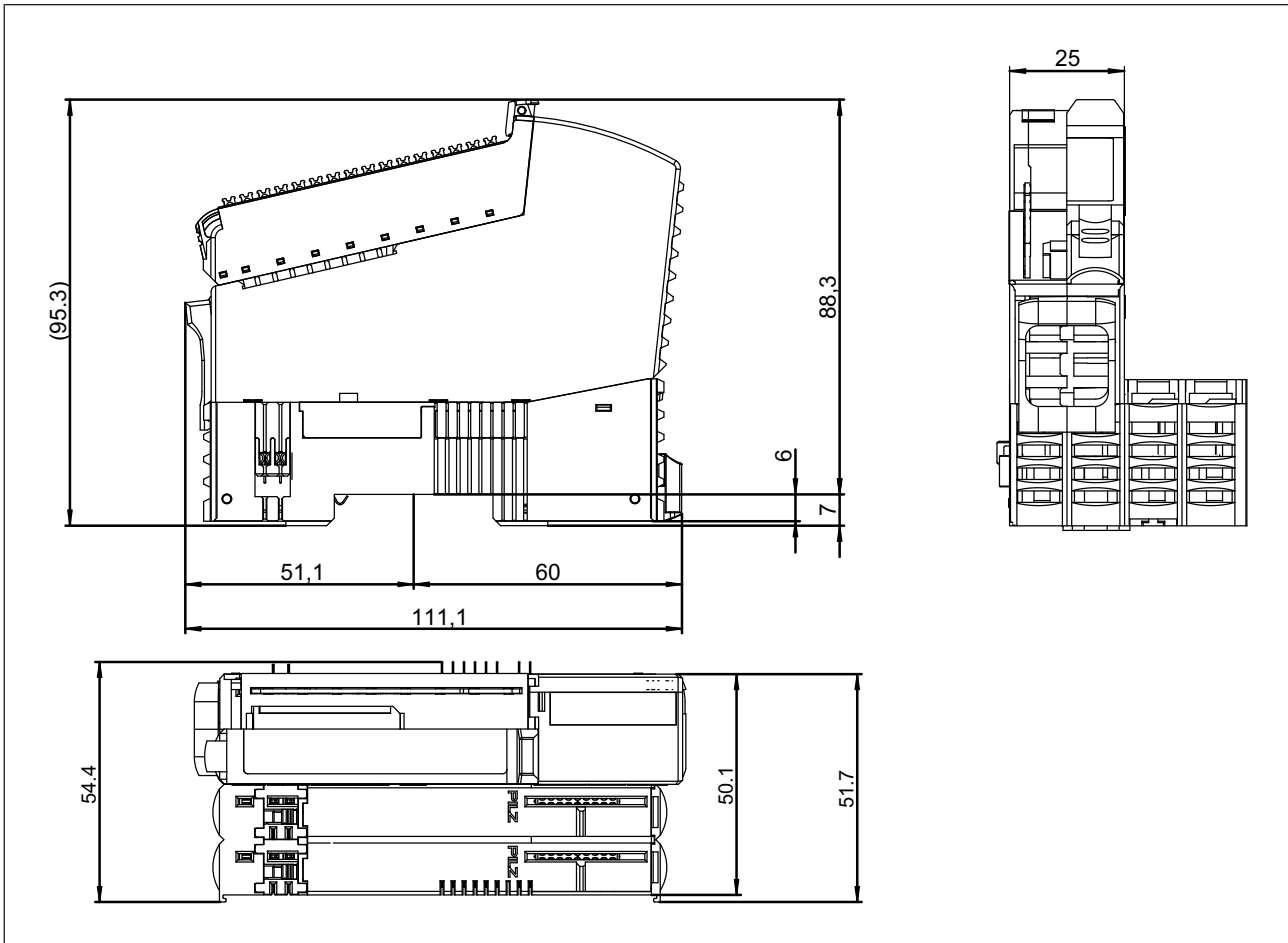
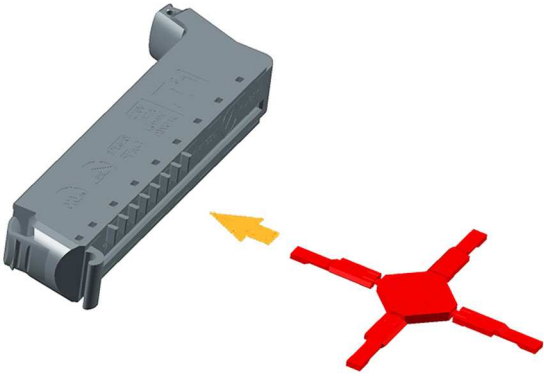
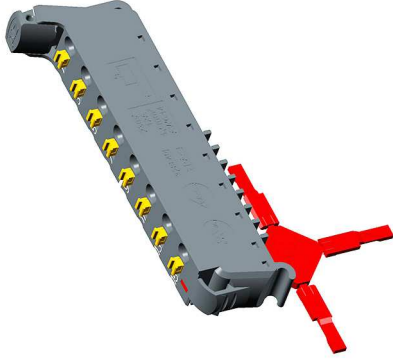
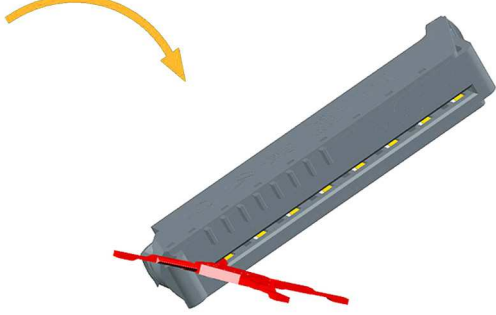
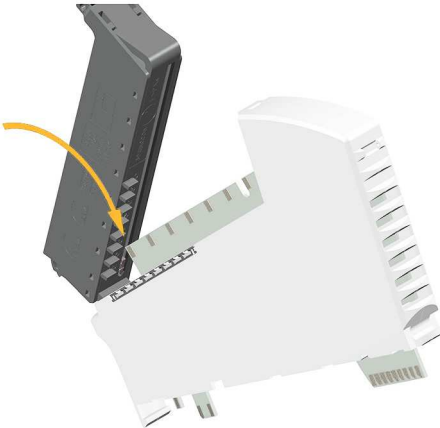

Fig.: Dimensions in mm, including backplane, electronic module and terminal block

6.2 Protective coding on terminal block

If voltages over 50 VAC or 120 VDC are connected to a module's switch contacts, then protective coding must be used. Protective coding prevents the terminal block from being plugged into another module.

<p>1. Insert the protective coding into the 8-pin terminal block</p>	
<p>2. The protective coding must be visible on the terminal side</p>	
<p>3. Rotate the protective coding until it is embedded within the terminal block.</p>	
<p>4. Plug the coded terminal block into the module.</p>	

6.3 Inserting and removing an electronic module

Please note:

- ▶ Backplane must be installed first.
- ▶ Electronic modules may only be plugged or unplugged if the terminal block has been removed first.
- ▶ The mechanics of the electronic modules are designed for 20 plug in/out cycles.
- ▶ On electronic modules with outputs, the terminal block may only be inserted and removed when the load is switched off. Unforeseeable error reactions may be triggered if modules are inserted and removed under load.

6.3.1 Inserting an electronic module

1. Insert the electronic module into the suspension lug on the backplane.

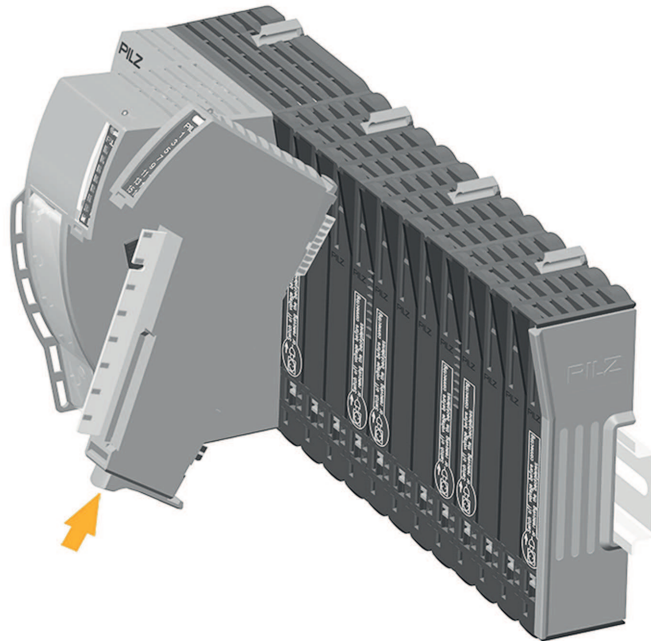

2. Swivel the electronic module downwards until you hear it click into place.

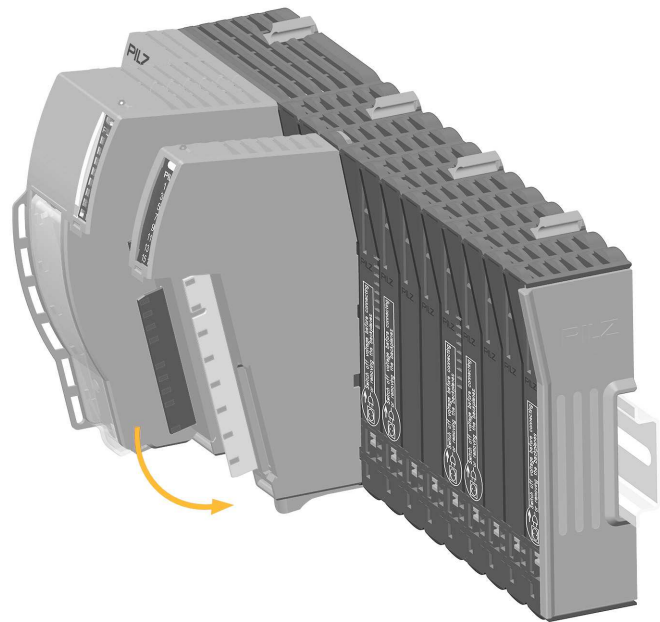

3. Insert the terminal block into the suspension lug on the module.

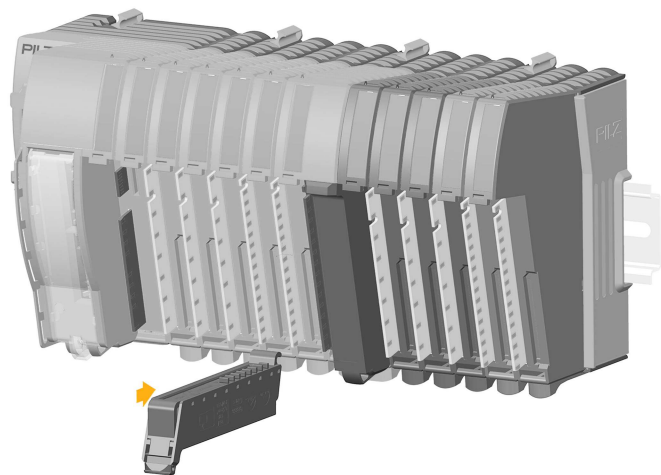

4. Swivel the terminal block downwards until you hear it click into place.

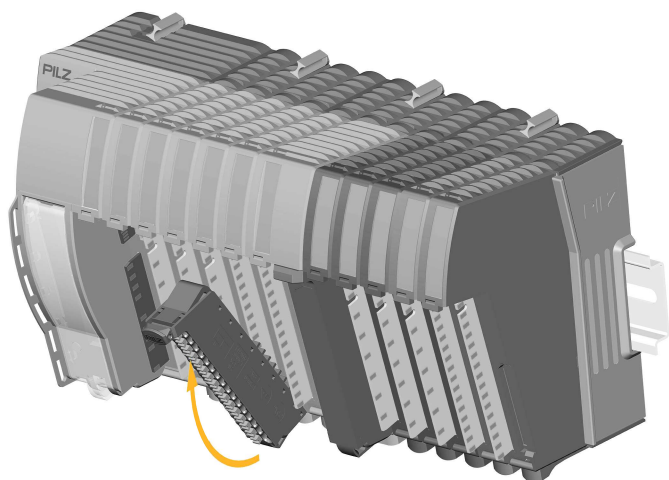

6.3.2 Removing an electronic module

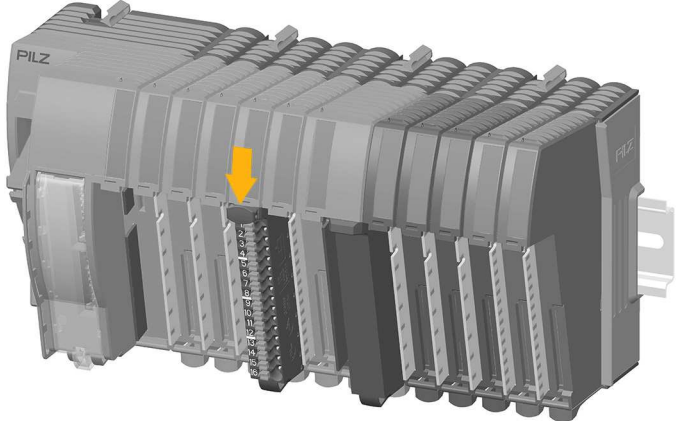
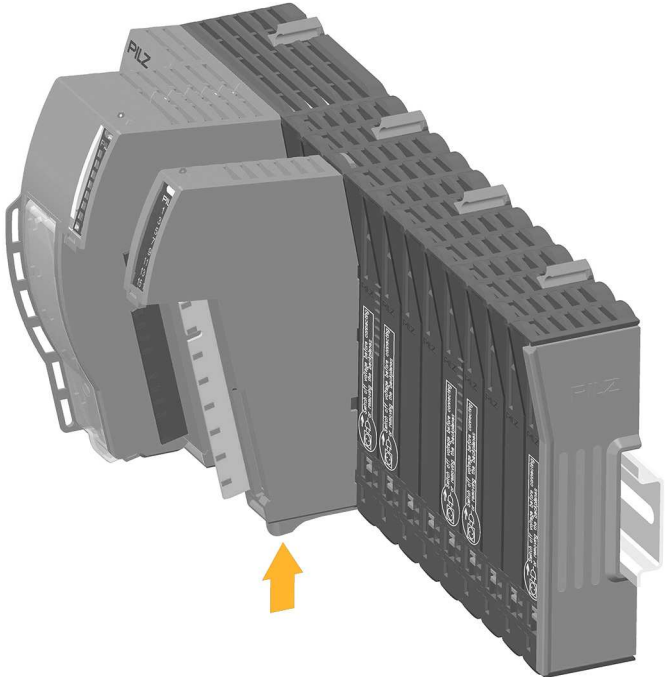
<p>1. Press the unlocking mechanism on the terminal block that is shown by the arrow and pull off the terminal block upwards.</p>	
<p>2. Press the unlocking mechanism that is shown by the arrow and pull off the electronic module upwards.</p>	

6.3.3 Changing an electronic module during operation

An electronic module can be hot swapped.

Effects:

- ▶ Module bus communication between the other modules is not interrupted.
- ▶ The configuration data is retained.
- ▶ The module is detected automatically as soon as the module is re-inserted.

A new electronic module can be inserted during operation.

Effects:

- ▶ Module bus communication between the other modules is not interrupted.
- ▶ The head module may need to be configured and restarted in order for the new module to be detected.

- ▶ On electronic modules with outputs, the terminal block may only be inserted and removed when the load is switched off. Unforeseeable error reactions may be triggered if modules are inserted and removed under load.

7 Wiring

7.1 General wiring guidelines

Please note:

- ▶ The actuators may be connected using unshielded cables.
- ▶ To prevent contact welding, a fuse should be connected before the output contacts (see Technical details).
- ▶ With inductive loads, sufficient fuse protection must be provided on all output contacts.
- ▶ If voltages higher than 50 VAC or 120 VDC are connected to the relay contacts, please note the following:
 - Specific accident prevention regulations apply.
 - These voltages must only be applied at the upper terminals (Ox3), to guarantee protection against contact when removing the terminal blocks.
- ▶ Use copper wiring.

7.1.1 Connection mechanism for terminal blocks

Procedure:

- ▶ Use a flat head screwdriver.
- ▶ Strip the wire back 9 mm.
- ▶ Feed the stripped cable as far as it will go into the opening for the spring-loaded terminal.
- ▶ Check that the cable is firmly seated.

Please note:

- ▶ The minimum cable cross section for field connection terminals on the terminal blocks is 0.15 mm² (AWG26).
- ▶ The maximum cable cross section for field connection terminals on the terminal blocks is 1.5 mm² with ferrules (AWG14)
- ▶ Use copper wiring.

7.2 Terminal configuration

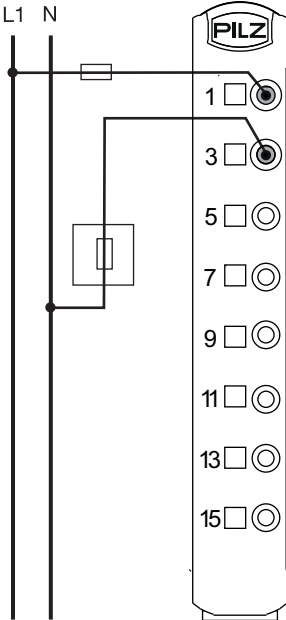
Terminal configuration	Connection examples
<p>Output O0 Terminal 1 - 3 Contacts: O0.13 - O0.14</p> <p>Output O1 Terminal 5 - 7 Contacts: O1.23 – O1.24</p> <p>Output O2 Terminal 9 - 11 Contacts: O2.33 – O2.34</p> <p>Output O3 Terminal 13 - 15 Contacts: O3.43 – O3.44</p>	<p>1-channel actuator</p> 

8 Operation

The status of the module is displayed via the "Module status display" and "Terminal status display"; this is signalled to the head module and any error is entered in the head module's diagnostic log.

8.1 Display elements and messages

Only the LEDs at the terminals 1, 5, 9, 13 are active.

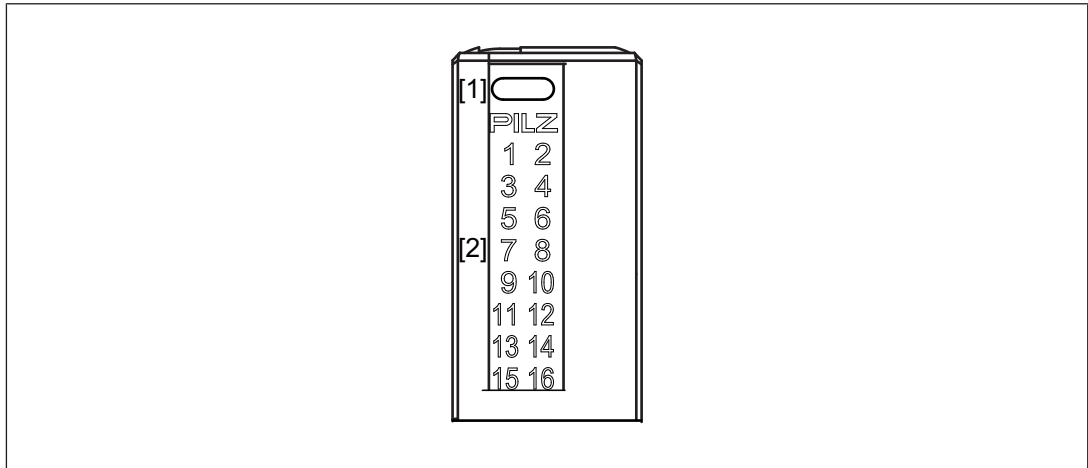



Legend

[1] Module status display

[2] Terminal status display

The module can detect the following errors:

[1]	Colour [1]	[2]	Colour [2]	Meaning	Further information
●	--	●	--	Module not ready for operation	
●	Green	●	--	Module ready for operation	
☀	Green	☀	Green	Module in operation and the relay contacts are closed	
☀	Green	●	--	Module in operation and the relay contacts are open	
●⚡	Red	●	--	Configuration error: Module was inserted in the wrong slot.	
☀	Red	●	--	Internal error/firmware update	See module's diagnostic log
●	Red	●	Green	The module status display and the terminal status display on the relevant output flash synchronously Short circuit/overload/undervoltage	See module's diagnostic log.
●	Red	●	Green	Temperature error: too warm (1)/warning, e.g. undervoltage	See module's diagnostic log

[1]	Colour [1]	[2]	Colour [2]	Meaning	Further information
	Red		Green	The module status display and all terminal status displays flash synchronously Periphery supply is missing/temperature error: Too hot (1)	See module's diagnostic log

(1) There are two levels of overtemperature.

▶ Too warm:

If the module temperature exceeds a threshold value, then:

- a warning is sent to the head module.

If the temperature drops back below the threshold value, the module sends an all-clear.





▶ Too hot:

If the module temperature exceeds another threshold value, then:

- an error message is sent to the head module
- the outputs are switched off
- The valid bits for the outputs are set to "0"

After the "too hot" message has been received, if the temperature drops back below the "too warm" threshold value, the module will switch to an error-free state.

Legend

-  LED on
-  LED flashes
-  LED flashes briefly
-  LED off

9 Technical Details

General	
Approvals	CE
Application range	Standard
Module's device code	001Eh
Number of ST output bits	4
Electrical data	
Internal supply voltage (module supply)	
Module's power consumption	0,2 W
Periphery's supply voltage (periphery supply)	
Voltage range	16,8 - 30 V
Module's current consumption with no load	40 mA
Module's power consumption with no load	1,2 W
Max. power dissipation of module	1,4 W
Permitted loads	inductive, resistive
Relay outputs	
Number of relay outputs	4
Max. processing time for relay output tProcOM when signal changes from "1" to "0"	50 ms
Max. processing time for relay output tProcOM when signal changes from "0" to "1"	50 ms
Contact material	AgSnO2
Environmental data	
Climatic suitability	EN 60068-2-1, EN 60068-2-14, EN 60068-2-2, EN 60068-2-30, EN 60068-2-78
Ambient temperature	
In accordance with the standard	EN 60068-2-14
Temperature range	0 - 55 °C
Storage temperature	
In accordance with the standard	EN 60068-2-1/-2
Temperature range	-40 - 70 °C
Climatic suitability	
In accordance with the standard	EN 60068-2-78
Humidity	93 % r. h. at 40 °C
Condensation during operation	Not permitted
Max. operating height above sea level	2000 m
EMC	EN 61131-2 (Zone B)
Vibration	
In accordance with the standard	EN 60068-2-6
Frequency	8,4 - 150 Hz
Acceleration	10 m/s ²

Environmental data	
Shock stress	
In accordance with the standard	EN 60068-2-27
Acceleration	150 m/s²
Duration	11 ms
Airgap creepage	
In accordance with the standard	EN 60664-1
Overvoltage category	III
In accordance with the standard	EN 61131-2
Overvoltage category	II
Pollution degree	2
Protection type	
In accordance with the standard	EN 60529
Housing	IP20
Mounting area (e.g. control cabinet)	IP54
Potential isolation	
Potential isolation between	Relay output and relay output
Type of potential isolation	Protective separation
Rated surge voltage	6000 V
Potential isolation between	Relay output and periphery supply
Type of potential isolation	Protective separation
Rated surge voltage	6000 V
Potential isolation between	Relay output and module supply
Type of potential isolation	Protective separation
Rated surge voltage	6000 V
Potential isolation between	Periphery supply and module supply
Type of potential isolation	Functional insulation
Rated surge voltage	2500 V
Mechanical data	
Mechanical life	50,000,000 cycles
Material	
Housing	PPE
Mounting type	plug-in
Dimensions	
Height	110,8 mm
Width	25 mm
Depth	75,3 mm

Where standards are undated, the 2017-05 latest editions shall apply.

9.1 Service life graphs

The service life graphs indicate the number of cycles from which failures due to wear must be expected. The wear is mainly caused by the electrical load; the mechanical load is negligible.

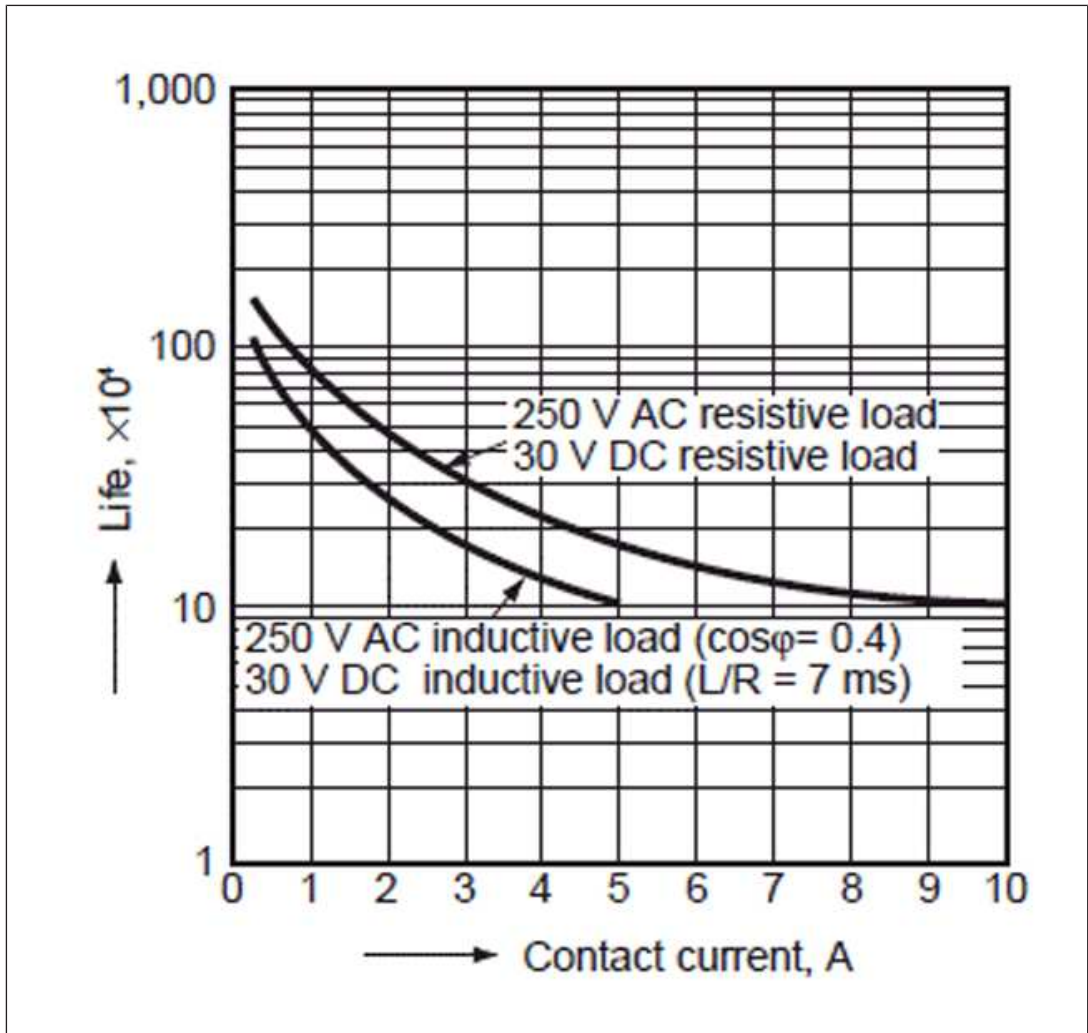

Fig.: Service life graph

We recommend you use semiconductor outputs to switch 24 VDC loads.

10 Order reference

10.1 Product

Product type	Features	Order no.
PSS u2 ES 4DO R 8A	Electronic module	328 420

10.2 Accessories

Terminal block

Product type	Features	Order No.
PSS u2 T 8 (1 pc.)	Terminal block 8-pin, 1 piece	328 840
PSS u2 T 8 (10 pcs.)	Terminal block 8-pin, 10 pieces	328 841
PSS u2 T 8 (5 x 10 pcs.)	Terminal block 8-pin, 50 pieces	328 842

Label holder for electronic module

Product type	Features	Order No.
PSS u2 A LC E1 (10 pcs.)	Label holder 23.5 x 10.5 mm, 10 pieces	328 910
PSS u2 A LC E2 (10 pcs.)	Label holder 103 x 10.5 mm, 10 pieces	328 911
PSS u2 A LA E1 (10 pcs.)	Labelling strips 23.5 x 10.5 mm (10 x DIN A4 sheet)	328 913
PSS u2 A LA E2 (10 pcs.)	Labelling strips 103 x 10.5 mm (10 x DIN A4 sheet)	328 914

Plastic clip terminal block

Product type	Features	Order no.
PSS u2 A LC T3 (10 pcs.)	Plastic clip terminal block 61 x 11.5 mm, 10 pieces	328 912

Coding elements

Product type	Features	Order No.
PSS u2 A CE E (10 pc.)	Coding elements, 10 pieces	328 860
PSS u2 A CE T (10 pc.)	Coding strip, 10 pieces	328 861

Backplanes

Product type	Features	Order no.
PSS u2 B 1	Backplane, 1 slot	328 811
PSS u2 B 4	Backplane, 4 slots	328 810

Shield connection element

Product type	Features	Order no.
PSS u2 A SH 4	Shield connection element for module rack with 4 slots	328 820
PSS u2 A LC B4	Inscription holder for module rack	328 916

Protective coding for terminal block

Product type	Features	Order no.
PSS u2 A CE T (10 pc.)	Protective coding, 10 pieces	328 861